



# Installation and Troubleshooting Guide



NOTE: This installation is to be completed by an Authorized Dealer or Professional Service Technician. For questions regarding installation or warranty, call CDI Tech Support at 866-423-4832. **Do not return to the Dealer or Distributor where the part was purchased. Contact CDI Electronics Directly for Return Material Authorization.**

## CDI P/N: 113-4489 Power Pack Conversion Kit 2 Cylinder

This kit will replace the following P/N's: 583656, 583664, 583665, 583896, 583984, 584329, 584331, 584347, 584486, 584487 and 584489.

**WARNING!** This product is designed for installation by a professional marine mechanic. CDI Electronics cannot be held liable for injury or damage resulting from improper installation, abuse, neglect or misuse of this product.

### INSTALLATION

1. Disconnect the negative battery cable.
2. Clean all battery cable connections and engine grounds.
3. Remove the flywheel.
4. Disconnect the Orange and Orange/Blue ignition coil wires.
5. Remove the base assembly with the old CD module mounted on it.
6. Remove the old power pack from the timer base plate and save the mounting bolts.
7. Cut the Black/Yellow kill wire close to the old power pack and save the wire.
8. Disconnect the Charge coil wires from the old CD module.
9. Replace the old charge coil with the new one (Remember to install the shunt plate on the outside of the charge coil **ONLY IF THE OLD CHARGE COIL HAD A SHUNT PLATE INSTALLED**). Bend the top lamination up and the bottom lamination down to wedge the coil in place.
10. Route the charge coil wires and the new sensor wires through the top of the timer base plate.
11. Slide the charge coil and sensor wires through the new sleeving.
12. Install the new sensor and plate assembly (Plate side up). Set the air gap according to the service manual, using PN: 553-4994 Locator Ring. NOTE: On some engines, you may have to remove some of the excess aluminum on the original stator plate assembly in order for the new sensor plate assembly to mount correctly with the sensor plate being straight.
  - A) Place the 553-4994 Locator Ring over the outside of the sensor and stator assemblies, seating it over the mounting bosses in the armature plate.
  - B) Loosen the mounting screws holding the sensor and stator assemblies in place.
  - C) Slide the sensor and stator assemblies out against the Locator Ring and hold them in place.
  - D) Tighten the screws to 15-22 inch pounds and slide the Locator Ring off of the sensor and stator assemblies.
13. Install the clamp on top of the armature plate to position and secure the charge coil and sensor coil leads.
14. Slide the sleeving up to the armature plate to protect the wiring and install the cover on the bottom of the plate (align the notch in the cover with the notch in the plate).
15. Install the timer base assembly and connect the linkage.
16. Re-install the flywheel according to the service manual.
17. Mount the new power pack to the engine (or to the adapter plate if there are no mounting bosses for the power pack, keeping the wires to the inside edge of the plate). If needed, mount the adapter plate on the port side of the engine at the top of the water jacket.
18. Route the trigger and charge coil wires around and over to the new CD module,
19. Insert the charge wires and sensor wires into the 5 pin connector, matching the wire color pin locations to the power pack connector.
20. Check for DC voltage on the kill (stop) wire (usually Black/Yellow) with the key-switch in the on and off position. At no time should you see over 2 volts DC on this wire as severe damage to the power pack can occur.
21. Cut and strip approximately 3/16" of insulation from the Black/Yellow wire and crimp the terminal furnished. Insert the Black/Yellow wire into the 5 pin connector.
22. Connect the Tan temperature wire to the temperature sensor.
23. Connect the Orange to the bottom (#2) ignition coil and Orange/Blue wire to the top (#1) ignition coil.
24. Re-connect the battery cable,
25. Reset ignition timing according to the service manual.

CDI Electronics • 353 James Record Road SW • Huntsville, AL 35824 USA

Web Support: [www.cdielectronics.com](http://www.cdielectronics.com) • Tech Support: 1-866-423-4832 • Order Parts: 1-800-467-3371

All rights reserved. Reproduction or use of content, in any manner, without express written permission by CDI Electronics, Inc., is prohibited.

NOTE: This installation is to be completed by an Authorized Dealer or Professional Service Technician. For questions regarding installation or warranty, call CDI Tech Support at 866-423-4832. **Do not return to the Dealer or Distributor where the part was purchased. Contact CDI Electronics Directly for Return Material Authorization.**

## TROUBLESHOOTING

### NO FIRE ON ANY CYLINDER:

1. Check the cranking speed, the engine should be turning 250 RPM or more. (Check the battery and starter).
2. Disconnect the Black/Yellow Kill wire from the power pack. If fire returns, there is a problem in the Kill circuit.
3. Check the stator resistance (450-850 ohms) and DVA output voltage while the stator is connected to the power pack. You should read 150V or more from the brown wire to the brown/yellow wire while they are connected to the pack. If low, disconnect the brown and brown/yellow wires from the pack and retest. If the voltage jumps to over 225V – the pack is likely bad. A reading that remains below 175V usually indicates a bad stator.
4. Check the trigger resistance and output. From the black/white to the white/black should read 38-43. DVA output should read 0.5V or more from the black/white to the white/black trigger wire, (Connected to the pack) while cranking the engine.
5. Check the DVA voltage on the Kill wire coming out of the power pack. You should read over 150 volts. If it is low, disconnect the Orange/Blue and the Orange/Green wires one at a time. If fire returns on one cylinder when the coil primary wire is disconnected from the other coil, the coil not connected and the power pack has to be replaced at the same time. The defective ignition coil blew the power pack.

### NO FIRE ON ONE CYLINDER:

1. Check the DVA voltage on the Kill wire coming out of the power pack. You should read over 150 volts.
2. Swap the orange coil wire of the cylinder not firing with the one that does on the pack and see if the fire moves from one coil to the other one. If it does, the pack is likely bad. If the fire stays on the same cylinder, the ignition coil is probably bad.
3. Swap the Blue trigger wire with the Green trigger wire and retest. If the fire moves from one cylinder to the other, replace the trigger. If it does not move, the pack is likely bad.
4. Swap the Brown stator wire with the Brown/Yellow stator wire and retest. If the fire moves from one cylinder to the other, replace the stator.

### WILL NOT ACCELERATE OVER 2500 RPM AND SHAKES VIOLENTLY

SLOW circuit may be activating:

1. Check the engine temperature and verify that the engine is not overheating.
2. Check the location of the Tan temperature sensor wire. It should not be located too close to a spark plug wire.
3. Disconnect the Tan temperature sensor wire at the pack and retest. If the engine now operates normally, replace the temperature sensor.
4. If the engines still acts up, replace the power pack.

### SLOW circuit will not activate

Disconnect the tan temperature wire and short it to engine ground.

*If the SLOW circuit now operates, replace the temperature sensor.*

*If the SLOW circuit still does not work, replace the power pack.*

NOTE: This installation is to be completed by an Authorized Dealer or Professional Service Technician. For questions regarding installation or warranty, call CDI Tech Support at 866-423-4832. **Do not return to the Dealer or Distributor where the part was purchased. Contact CDI Electronics Directly for Return Material Authorization.**

## CD2 DIAGRAM

### 113-4488 and 113-4489 CD2 USL Conversion Kit Assembly

( Fig:1 )

1. Remove flywheel.
2. Remove original CD2 USL from the timer base plate.
3. Mount the CDI sensor on the plate where the original CD2 USL was removed.  
See diagram for proper mounting.
4. Set the air-gap according to the factory service manual using the CDI gauge P/N: 533-4994.
5. Secure the mounting screws using Loctite adhesive.
6. Route the lead wires for the electrical connections.

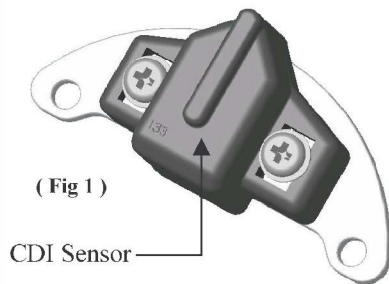

Specifications  
Install ( Fig: 2 )

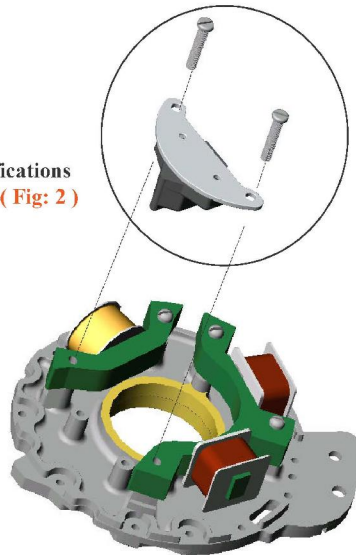

( FIG:2 )

1. Remove the single charge coil from the timer base plate.
2. Remove original coil from the lamination.
3. Place the new high voltage coil P/N: 173-1670 onto the lamination post.
4. Bend the outer lamination to secure the coil to the lamination.
5. Install the new assembly back on to the plate. Use loctite to secure the bolts.
6. Route the lead wires for the electrical connections.

High voltage Coil

( Fig 2 )

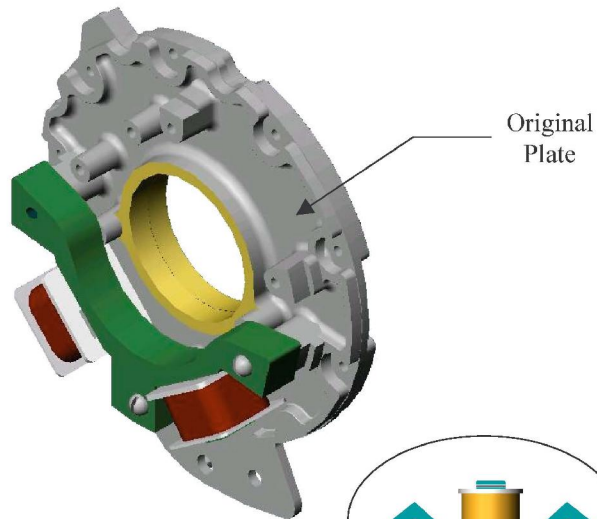
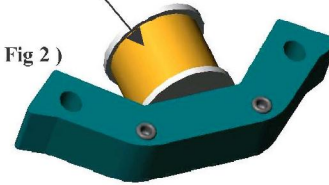

Specifications  
Install ( Fig: 1 )

